

Presented To:	Operations Committee
Presented:	Monday, Jul 08, 2013
Report Date	Friday, Jun 28, 2013
Type:	Managers' Reports

Request for Decision

Pedestrian Traffic Signals - Barry Downe Road at Woodbine Avenue

Recommendation

THAT the City of Greater Sudbury approve the installation of a pedestrian refuge island on the north approach of Barry Downe Road at Woodbine Avenue as part of the 2013 Capital Construction Program; and

THAT the widening of Barry Downe Road to provide a continuous two-way centre left turn lane between Sparks Street and Woodbine Avenue be given a high priority; and

THAT Staff continue to monitor pedestrian and vehicle volumes at this intersection to determine if pedestrian signals or full traffic signals should be included as part of any future widening.

Background

At the Operations Committee meeting held on May 6, 2013, Councillor Landry-Altmann submitted a petition signed by 501 citizens requesting a safe crossing system for pedestrians to cross Barry Downe Road at Woodbine Avenue (see Exhibit I). At the same Operations Committee meeting, Councillor Landry-Altmann also presented the following Notice of Motion which was carried by the Committee:

OP2013-29 Landry-Altmann/Berthiaume: WHEREAS on May 23rd of 2007, Council of the City of Greater Sudbury passed Resolution #2007-226 which stated:

“AND BE IT FURTHER RESOLVED that the City of Greater Sudbury accept the challenge to become the most pedestrian friendly city in Ontario by 2015;

AND BE IT FURTHER RESOLVED that the Council of the City of Greater Sudbury consider both the International Charter for Walking and the challenge in future planning, transportation, infrastructure and leisure decisions”;

AND WHEREAS the Official Plan adopted in June of 2006 identifies that sidewalks, bike lanes, bike paths and walking trails need to be fully integrated components of the overall transportation system, providing safe access for pedestrians and cyclists supported by good urban design principles, and that opportunities to engage in recreational and leisure activities are also tied to the transportation network;

AND WHEREAS the Sustainable Mobility Plan received by Council in 2010, states as one goal that in order to build a safe, caring and welcoming community, a City must provide affordable access to employment, educational, health, cultural and recreational facilities for everyone including its most vulnerable;

Signed By

Report Prepared By

Dave Kivi
Co-ordinator of Transportation & Traffic
Engineering Services
Digitally Signed Jun 28, 13

Division Review

David Shelsted
Director of Roads & Transportation
Services
Digitally Signed Jun 28, 13

Recommended by the Department

Tony Cecutti
General Manager of Infrastructure
Services
Digitally Signed Jun 28, 13

Recommended by the C.A.O.

Doug Nadorozny
Chief Administrative Officer
Digitally Signed Jun 28, 13

AND WHEREAS between 2004 and 2008 an average of 329 cyclists and 90 pedestrians per year sustained an injury which required a hospital visit; in 2009, 4 pedestrians and 1 cyclist died travelling through the city; and more recently, between 2010 and 2012, the City of Greater Sudbury incurred 4 pedestrian fatalities, 3 on Lasalle Boulevard and 1 in the Valley as well as many cyclist/motorist injuries;

AND WHEREAS the traffic circulation on Barry Downe Road increases by about 5,000 during the school year, particularly during the Cambrian College school term;

AND WHEREAS the residents of New Sudbury, Ward 12, have witnessed and reported many incidences along the Barrydowne Road, Woodbine Avenue to Lillian Boulevard corridor;

AND WHEREAS a petition has been submitted by the Ward 12 New Sudbury Community Action Network from residents of that area, students of Cambrian College and Lasalle Secondary School requesting a pedestrian connection between Woodbine Avenue through Barry Downe Road, east to west via a pedestrian walk light;

AND WHEREAS a sidewalk/bike lane connecting Lillian Boulevard to Woodbine Avenue request has been made, in light of the latest incident involving a wheelchair occupant;

AND WHEREAS residents and students have a long outstanding request (since 2008) for a transit shelter at the corner of Lillian Boulevard and Barry Downe Road;

THEREFORE BE IT RESOLVED THAT City of Greater Sudbury Staff be directed to report to the Operations Committee in July of 2013 regarding Options and costs for:

1. A pedestrian walk light at Woodbine Avenue and Barry Downe Road;

BE IT FURTHER RESOLVED THAT in preparation of the report, historic traffic warrants taken at peak times during the school term, most particularly during Cambrian College's school term, be utilized.

The following Staff Report will analyze recent traffic counts and present four Options and costs to improve pedestrian safety. The Option of doing nothing is also reviewed.

The intersection of Barry Downe Road and Woodbine Avenue is located approximately 600 metres north of LaSalle Boulevard (see Exhibit II). In this area, Barry Downe Road is constructed with four lanes of traffic, has an AADT of 10,500 and a speed limit of 50 km/h. The sidewalk on the west side of Barry Downe Road ends at this intersection and the sidewalk along the east side continues north approximately 30 metres to the southerly entrance to Cambrian College.

In 2007, Staff reviewed the need for pedestrian crossing facilities at all the unsignalized intersections along Barry Downe Road, north of LaSalle Boulevard including Barry Downe Road and Woodbine Avenue. The Staff Report dated July 26, 2007 was presented to City Council on August 8, 2007 (see Exhibit III).

Based on a traffic count conducted in May 2007, the pedestrian volume crossing Barry Downe Road at this intersection was less than 40% of the minimum required to warrant pedestrian traffic signals. The vehicle and pedestrian volumes were 66% of the minimum required for full traffic signals. The traffic count identified that a northbound left turn lane was warranted at the intersection.

The report recommended that pedestrian warning signs be installed on both sides of Barry Downe Road in the study area which was completed at that time. The report also recommended that a continuous two-way centre left turn lane constructed between Sparks Street and Woodbine Avenue and that pedestrian volumes be monitored to determine if pedestrian signals or raised islands should be included as part of any future widening.

At the Council meeting, Staff was requested to complete a second count at the intersection of Barry Downe Road and Woodbine Avenue while regular classes were in session at Cambrian College. As a result, Staff conducted a seven hour manual turning movement count at this location on December 6, 2007. This count showed that pedestrian crossing volumes were higher than previously recorded but still only 47% of the minimum warrants for pedestrian signals. Vehicle volumes were also higher than the previous count but still only 74% of the minimum required to warrant full traffic signals.

The intersection of Barry Downe Road and Woodbine Avenue was most recently counted on April 12, 2011, while regular classes at Cambrian College were ongoing. The pedestrian crossing volumes recorded were higher than the

previous counts with a total of 161 pedestrians. There were no seniors, young children or disabled persons that crossed Barry Downe Road during the count. Applying the pedestrian crossing volumes to the pedestrian signal warrants indicates that they are 59% of the minimum required for the installation of intersection pedestrian signals.

When the vehicle and pedestrian volumes were applied to the warrants for full traffic signals, the results show that they were 79% of the minimum to warrant full traffic signals.

A review of the City's collision information at the intersection for the three year period from 2010 to 2012 inclusive, revealed there were a total of three collisions that may have been preventable if traffic signals were installed. There were no collisions involving pedestrians during the three year period. The warrants for traffic signals based on safety requires there be a minimum of five collisions per year over a three year period.

In March 2012, the City approved a Pedestrian Crossing Policy that recommends that the methodologies and thresholds contained in the Ontario Traffic Manual be used to accommodate protected pedestrian crossings such as traffic control signals, mid-block traffic signals and intersection pedestrian signals. The methodologies and warrants contained in the O.T.M. are the same as used by Staff under previous reviews.

The four Options reviewed by Staff include Intersection Pedestrian Signals, Full Traffic Control Signals and a Pedestrian Refuge Island. The Option of doing nothing is also reviewed.

Option #1 – Intersection Pedestrian Signals

Intersection pedestrian signals provide a protected crossing for pedestrians. With this Option, pedestrians crossing Barry Downe Road are controlled at a crosswalk with pedestrian signal displays on the north approach of the intersection. Traffic on Barry Downe Road is controlled with regular traffic signal displays, where traffic on Woodbine Avenue continues to be controlled with a stop sign (see Graphic #1 attached). The intersection of Paris Street and the entrance to Southwind Retirement Residence is an example of an intersection pedestrian signal. This type of protected crossing is appropriate when traffic volumes on the minor road are very light, but have high pedestrian volumes. The estimated cost to install intersection pedestrian signals is \$90,000.00 to \$110,000.00.

As previously indicated, the existing vehicle and pedestrian crossing volumes do not meet the minimum requirements for intersection pedestrian signals or full traffic signals. Based on the relatively high traffic volumes on Woodbine Avenue, intersection pedestrian signals are not recommended at this location.

Option #2 – Full Traffic Control Signals

Full traffic control signals provide a protected pedestrian crossing on all approaches of the intersection. This Option provides vehicle and pedestrian displays for all three approaches (see Graphic #2 attached).

The estimated cost to install full traffic signals is \$150,000.00 to \$175,000.00. A review of the intersection revealed there is a large hydro line running above the boulevard along the east side of Barry Downe Road. The location of the hydro line and lack of City owned land behind the sidewalk will complicate the installation of traffic signals in order to satisfy the electrical code. Resolving this issue may increase the proposed costs provided above.

Although not warranted at this time, should Council decide to install a protected pedestrian crossing at this location, Staff recommends that a full set of traffic signals be installed. If this Option is chosen, a detailed design and cost estimate will need to be undertaken.

Option #3 – Pedestrian Refuge Island

A third Option to improve pedestrian crossing safety at the intersection is through the construction of a pedestrian refuge island on the north approach of the intersection (see Graphic #3 attached). As indicated in the City's Pedestrian Crossing Policy, "the presence of a pedestrian island simplifies the pedestrian crossing movement by providing a safe refuge in the centre of the road. Refuge islands reduce the distance required to cross and increase the available laps for pedestrians. They allow pedestrians to concentrate on crossing one direction at a time."

Pedestrian crossings with refuge islands are considered "unprotected" as pedestrians must yield right-of-way to vehicle traffic. However, they have been beneficial to pedestrian safety and security when installed on other multi-lane roads in the City. Signs are installed at refuge islands advising pedestrians to yield to traffic.

Although Barry Downe Road has four lanes at Woodbine Avenue, the second southbound through lane begins only 40 metres north of the intersection. As indicated above, by changing the pavement markings, room can be provided to construct a refuge island on the north approach of the intersection. This location would match the pedestrian desire line between Cambrian College and the sidewalk along the north side of Woodbine Avenue. Under this scenario, the start

of the second southbound lane would begin immediately south of the intersection.

The estimated cost of constructing the refuge island is approximately \$30,000.00.

Option #4 – Do Nothing

As a forth Option, Staff reviewed the possibility of leaving the intersection as is. As previously discussed, the vehicle and pedestrian volumes do not meet the warrants for a signalized “protected” crossing and there is not a minimum warrant for pedestrian refuge islands. While the crossing movement is simplified for pedestrians, the presence of a median island will hamper winter maintenance activities and costs approximately \$30,000.00 to construct. However, given the significant pedestrian crossing volume and high traffic volumes on Barry Downe Road, Staff does not recommend this Option.

RECOMMENDATION

In order to improve pedestrian safety, Staff recommends that a pedestrian refuge island be installed on the north side of Barry Downe Road at Woodbine Avenue. Also, that the work be included as part of this year’s Capital Construction Program and funded by the existing 2013 Capital Budget.

It is also recommended that widening Barry Downe Road to provide a continuous two-way centre left turn lane between Sparks Street and Woodbine Avenue be given a high priority. Also, that pedestrian crossing volumes be monitored at this intersection to determine if pedestrian signals or full traffic signals should be included as part of any future widening.

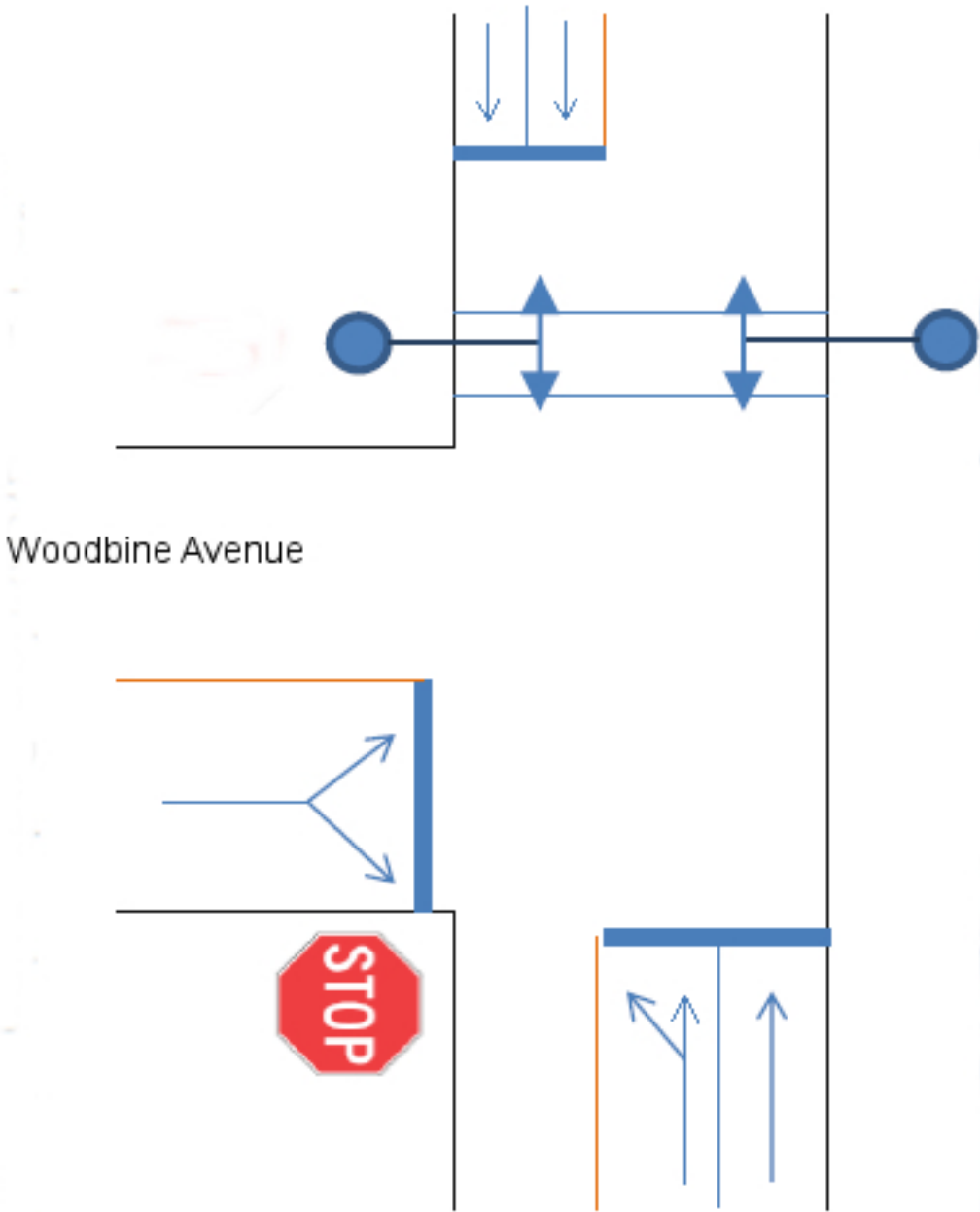

Woodbine Avenue

Intersection Pedestrian Signals

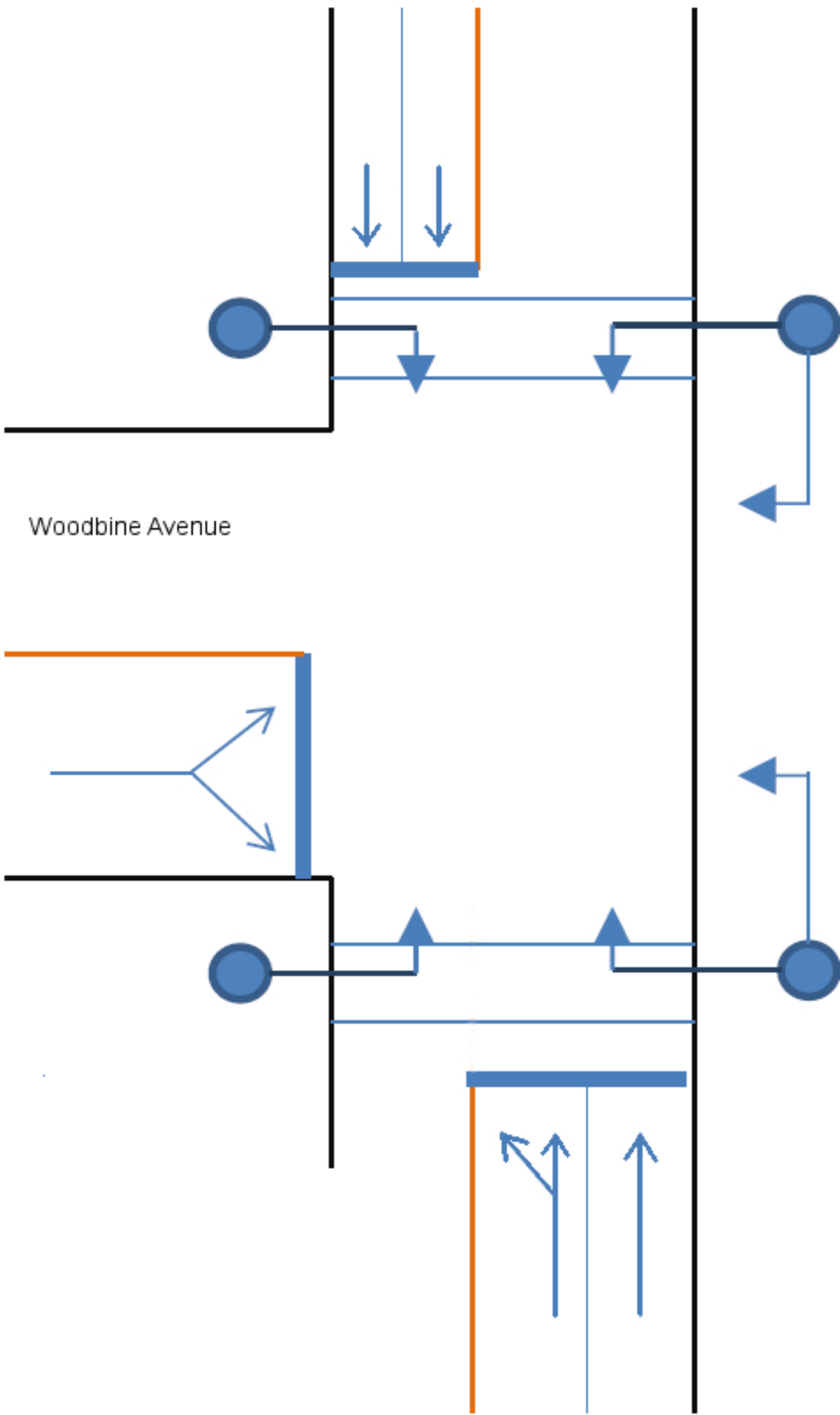

Full Traffic Control Signals

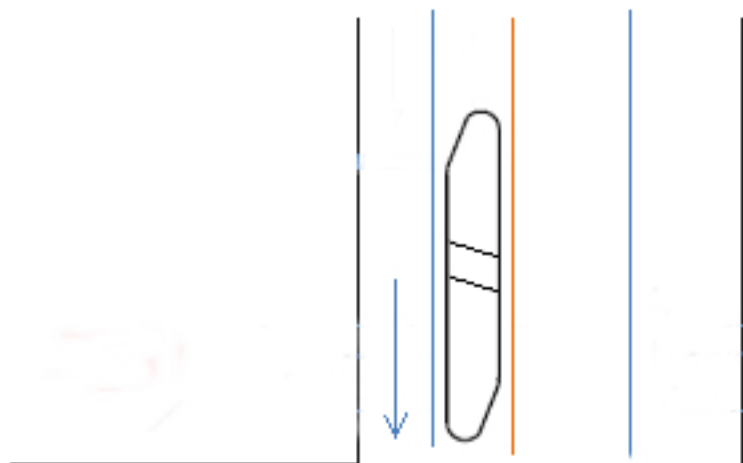

Woodbine Avenue

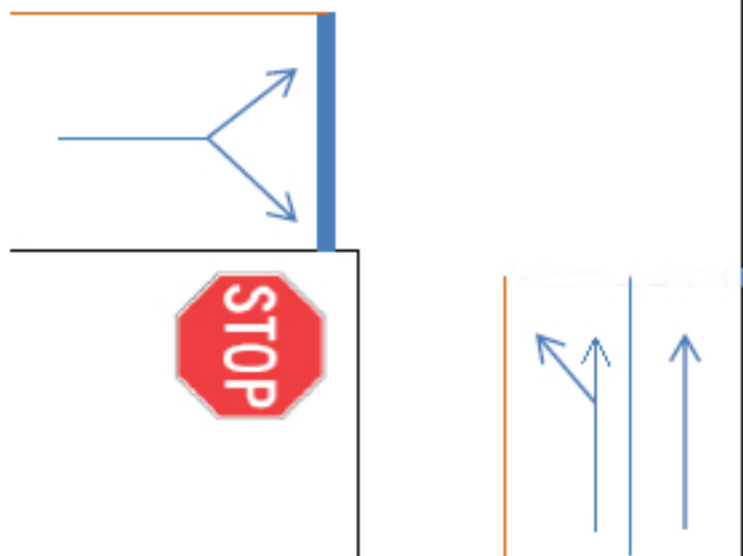

Pedestrian Refuge Island

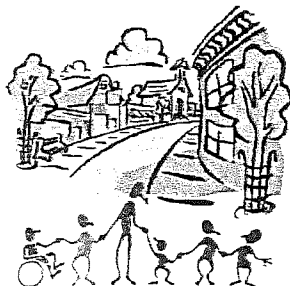

WARD 12 - QUARTIER 12
NEW SUDBURY COMMUNITY ACTION NETWORK (NSCAN12)
RÉSEAU D'ACTION COMMUNAUTAIRE DU NOUVEAU- SUDBURY (RACNS12)

www.newsudbury.ca www.nouveausudbury.ca

The residents of New Sudbury Ward 12 have requested many times for a safe crossing system to cross Barrydowne Road at Woodbine Avenue. Long distance spans between lights at Lillian and Lasalle Blvds. A combination of speeding vehicles and heavy traffic flow increases with each year and students of Cambrian College and Lasalle Secondary and area residents can no longer wait for the reconstruction of Barrydowne Road and therefore URGENTLY request the Traffic and Transportation Department to find a way to install a pedestrian traffic light system that will ensure the safety of all.

NAME	ADDRESS	POSTAL CODE
------	---------	-------------

EXHIBIT: II

GOVERNOR

MADISON

LAMOTHE

VOYAGEUR

PAQUETTE

CURLOK

Cambrian College

UNNAMED PRIVATE 107

College Entrance

KENNEDY

SPARKS

BARRY DOWNE

Subject Intersection

REDFERN

LINCOLN

LASALLE

KINGSLA

WOODBINE

HOLLAND

LAMOTHE

ARVO

ROY

AGINCOURT

HASTINGS

RINFRET

UNNAMED LANES

ATLEE

LEON

MCCORMACK

BELFRY

Pedestrian Traffic Signals

Barry Downe Road at Woodbine Avenue

June 24, 2013

Sheet II 1/1

**Request for Decision
City Council**





Type of Decision									
Meeting Date	August 8, 2007				Report Date	July 26, 2007			
Decision Requested	X	Yes		No	Priority	X	High		Low
	Direction Only				Type of Meeting	X	Open		Closed

Report Title
<p>Request for Pedestrian Signals</p> <ul style="list-style-type: none"> (1) Barry Downe Road at Sparks Street (2) Barry Downe Road at Kennedy Street (3) Barry Downe Road at Lamothe Street (4) Barry Downe Road at Woodbine Avenue

Budget Impact / Policy Implication	Recommendation
<p>This report has been reviewed by the Finance Division and the funding source has been identified.</p>	<p>To improve pedestrian safety, staff recommend that the following improvements be made; all in accordance with the report from the General Manager of Infrastructure Services dated July 26, 2007:</p> <ul style="list-style-type: none"> 1) That pedestrian warning signs be installed along both sides of Barry Downe Road in the study area. 2) That widening Barry Downe Road to provide a continuous two-way centre left turn lane between Sparks Street and Woodbine Avenue be given a high priority to improve pedestrian safety. 3) That the pedestrian crossing volumes be monitored along Barry Downe Road to determine if pedestrian signals or raised islands should be included as part of any future widening.
<p>X Background Attached</p>	<p>Recommendation Continued</p>

Recommended by the Department	Recommended by the C.A.O.
<p>Greg Clausen, P. Eng. General Manager of Infrastructure Services</p>	<p>Mark Mieto Chief Administrative Officer</p>

Date: July 26, 2007

Report Prepared By	Division Review
 Dave Kivi, Co-ordinator of Transportation and Traffic Engineering Services	 Robert M. Falcioni, P.Eng. Director of Roads and Transportation

Background:

At the City Council meeting on February 14, 2007, Councillor Landry-Altman submitted a petition requesting the installation of pedestrian signals at the intersection of Barry Downe Road and Lamothe Street (see Exhibit "A"). The petition indicated that the signals would improve safety for people crossing Barry Downe Road as well as slow traffic down.

Forms of Pedestrian Crossings

The Highway Traffic Act indicates that there are fundamentally two different forms of pedestrian crossings. The crossings may be either:

- A protected crossing where vehicles must yield to pedestrians, or
- An unprotected crossing where pedestrians must yield to vehicles.

Protected crossings include those locations where there is traffic control that requires a vehicle to yield or stop, such as a traffic control signal, an intersection pedestrian signal, a pedestrian crossover with flashing lights, a stop sign, or a crossing guard.

An unprotected crossing may or may not have warning signage and in some jurisdictions, crosswalk pavement markings. An unprotected crossing may also have no designation or traffic control measures but is a location where there is measurable pedestrian crossing activity. Safety at unprotected crossings can also be improved with the addition of warning signs or the construction of refuge islands or centre medians.

Either form of crossing may be appropriate given a range of pedestrian demand. There is generally a higher degree of concern for pedestrian safety at unprotected crossing points. However, both forms of crossings must be designed to maximize safety.

Some types of protected crossings that may be appropriate for Barry Downe Road are traffic control signals, intersection pedestrian signals, or mid-block pedestrian signals.

The City of Greater Sudbury follows the Ontario Ministry of Transportation's warrants for the installation of the various pedestrian signal control devices. The warrants are based on the number of pedestrians crossing the road, traffic volumes and geometric considerations such as: number of lanes; speed limits; and proximity of existing signal devices. The estimated cost to install intersection or mid-block pedestrian signals is \$80,000. The cost of full traffic control signals can be as high as \$170,000.

Date: July 26, 2007

To determine the type and location of pedestrian facilities that may be required for Barry Downe Road, seven (7) hour turning movement counts and pedestrian crossing counts were conducted at the following locations, which are shown on Exhibit "B":

- (1) Barry Downe Road at Sparks Street
- (2) Barry Downe Road at Kennedy Street
- (3) Barry Downe Road at Lamothe Street
- (4) Barry Downe Road at Woodbine Avenue

To incorporate the special needs of seniors, young children, and disabled persons, the total number of crossings were increased by twenty (20) percent before being applied to the warrants. All counts were conducted in May 2007 while elementary schools and Lasalle Secondary School were in session. Pedestrians that crossed Barry Downe Road mid-block were assigned to the nearest intersection.

1) Barry Downe Road at Sparks Street

The intersection of Barry Downe Road and Sparks Street is located approximately 90 metres north of a signalized intersection at Lasalle Boulevard. This section of Barry Downe Road is constructed with four (4) lanes of traffic, and a sidewalk along both sides. It carries an average annual daily traffic volume (AADT) of 13,000 vehicles and has a posted speed limit of 50 km/h.

A summary of the pedestrian and vehicle counts is contained in Exhibit "C". The pedestrian and vehicle volumes were applied to the warrants for both pedestrian signals and full traffic signals and the results show that signals are not justified. The factored pedestrian volume is 67 where 260 would be required. Also, the intersection is too close to the existing traffic signals at Lasalle Boulevard to install a new set of signals. A minimum spacing of 215 metres is recommended between traffic signals as recommended by the Ontario Traffic Manual.

The turning movement count data does indicate that left turn lanes are warranted on Barry Downe Road in both directions of travel.

2) Barry Downe Road at Kennedy Street

The intersection of Barry Downe Road and Kennedy Street is located approximately 210 metres north of Lasalle Boulevard. This section of Barry Downe Road is constructed with four (4) lanes of traffic and sidewalks along both sides. It carries an AADT of 11,000 vehicles north of Kennedy Street and has a posted speed limit of 50 km/h. Lasalle Secondary School is located at the east end of Kennedy Street.

A summary of the pedestrian and vehicle count data is contained in Exhibit "D". The pedestrian and vehicle volumes were compared to the warrants for both pedestrian signals and full signals, and the results show that neither are required at this time. The factored pedestrian crossing volume is 115 where 250 would be required to satisfy the minimum requirements for pedestrian signals. The vehicle and pedestrian volumes are only 17 percent of the minimum required to warrant full traffic signals.

The turning movement count data does indicate that a southbound left turn lane is warranted on Barry Downe Road at Kennedy Street.

Date: July 26, 2007

3) Barry Downe Road at Lamothe Street

The intersection of Barry Downe Road and Lamothe Street is located approximately 330 metres north of Lasalle Boulevard. The entrance to St. Andrew The Apostle Church is located opposite Lamothe Street forming a four (4) way intersection. This section of Barry Downe Road also has four (4) lanes of traffic and a sidewalk along both sides. It carries an AADT of 11,000 vehicles and has a posted speed limit of 50 km/h.

In response to concerns about parishioners crossing Barry Downe Road to attend the church services, a special count was conducted on Sunday, June 3, 2007, from 8:30 a.m. to 12:30 p.m. A summary of the weekday pedestrian and vehicle counts and the special Sunday pedestrian count can be found in Exhibit, "E" & "F". The results of the count data show that pedestrian signals and full traffic control signals are not warranted at this time. The adjusted pedestrian volume for weekdays is 63 where a minimum volume of two hundred and seventy five (275) crossings is required to satisfy the warrants for pedestrian signals. The Sunday pedestrian crossing count indicated a total of sixty eight (68) pedestrians crossed the road during the four (4) hour period. The majority of crossings were to and from the church which has Sunday morning services. While an (eight) 8 hour pedestrian crossing volume is not known, it would be much less than 325 crossing required for the installation of pedestrian signals. The turning movement count data does indicate that a north bound left turn lane is warranted at this intersection.

4) Barry Downe Road at Woodbine Avenue

The intersection of Barry Downe Road and Woodbine Avenue is located approximately 480 metres south of the signalized intersection of Barry Downe Road and Lillian Boulevard (see Exhibit "B"). In this area, Barry Downe Road is constructed with four (4) lanes of traffic, has an AADT of 10,500 and a speed limit of 50 km/h. The sidewalk on the west side of Barry Downe Road ends at this intersection, and the sidewalk along the east side continues north approximately 30 metres to the entrance to Cambrian College.

A summary of the pedestrian and vehicle count data is contained in Exhibit "G". The pedestrian and vehicle volumes were compared to the warrants for both pedestrian signals and full traffic signals, and the results show that neither are warranted at this time. The factored pedestrian volume is 114 where 300 is required for signals. The vehicle and pedestrian volumes are 66% of the minimum required for full traffic signals.

A review of the City's collision information from 2003 to 2005 inclusive showed that two (2) collisions occurred at the intersection involving three (3) pedestrians being struck by vehicles. A detailed review revealed that two (2) of the pedestrians were hit while crossing Woodbine Avenue and not Barry Downe Road.

The turning movement count data indicated that a northbound left turn lane is warranted at this intersection.

Summary of Findings

The above analysis indicates that while signals are not currently warranted at any single location, there is a significant number of pedestrians who currently cross this busy arterial roadway between Lasalle Boulevard and Woodbine Avenue. The traffic count information also indicated that left turn

Date: July 26, 2007

lanes on Barry Downe Road are warranted at each intersection within the study area.

To improve pedestrian safety, staff recommend that the following improvements be made:

- 1) That pedestrian warning signs be installed along both sides of Barry Downe Road in the study area.
- 2) That widening Barry Downe Road to provide a continuous two-way centre left turn lane between Sparks Street and Woodbine Avenue be given high priority to improve pedestrian safety. A centre left turn lane provides a refuge area for pedestrians, allowing them to cross against one direction of traffic at a time. It may also be possible to further protect pedestrians with the construction of raised islands in the centre of the road at some locations.
- 3) That the pedestrian crossing volumes be monitored along Barry Downe Road to determine if pedestrian signals should be included as part of any future widening.

Should Council decide to install pedestrian signals at one or more locations, staff recommend that Woodbine Avenue and Kennedy Street be given priority as Lasalle Secondary School and Cambrian College appear to be the largest pedestrian generators in the area. It has been found that pedestrians will not walk out of their way to use a protected crossing. This is evident at Sparks Street where 67 pedestrians crossed Barry Downe Road this unprotected location, even though it is located only 90 metres north of the traffic signals at Lasalle Boulevard.

As previously mentioned, the cost of pedestrian signals is approximately \$80,000. If pedestrian signals are approved, the Capital Budget for traffic signals would need to be increased accordingly, or an intersection that meets the warrants for traffic signals would need to be deferred until funding is available.

EXHIBIT: A



INTEROFFICE MEMO

February 20, 2007

TO: G. Clausen, Acting General Manager of Infrastructure
B. Falcioni, Director of Roads & Transportation

FROM: CJ Caporale, Council Secretary

RE: Petition - Pedestrian Lights at Lamothe Street & Barrydowne Road

At the City Council meeting of February 14, 2007, Councillor Landry-Altman submitted a petition to the City Clerk regarding the installation of pedestrian lights at the corner of Lamothe Street and Barrydowne Road, Sudbury.

A copy of the first page of the petition is attached for your review.

The complete petition (approximately ninety signatures) is available in the Clerk's Department if you wish to review it.

For your information.

CJ Caporale

cc: Councillor Landry-Altman

EXHIBIT: A

PETITION

Whereas there is no safe place to cross Barrydowne at Lamothe due to heavy traffic and whereas Cambrian College, Lasalle Secondary, parishioners of St. Andrew the Apostle Church, students from St Andrew separate school, Carl Nesbitt public school, residents of the neighbourhood take their lives in their own hands trying to cross. We petition the City of Greater Sudbury to install walking lights at Lamothe Street and Barrydowne Road. The space between the lights at Lilian Street and the lights at Lasalle is far too great a distance. Lights would help slow down the traffic. This light could be activated by the pedestrian.

- David Chisholm DAVID CHISHOLM
- Monique Fournier
- Ginelle Dupuis
- Kinck DeKrono
- Robert Therien
- Juliete Guerin
- John Bluff
- MON SMITH
- PAULINE BENOIT
- Jeff Netzke
- Roger Zumbault
- DAW CAUCIPEW
- BRANN YLINE
- Frank Marcano
- George M. Kelly
- Paul Lamontagne
- Thelma Coulter



February 20, 2007

Mr. David Chisholm

PO BOX 5000 SENA
200 BRADY STREET
SUDBURY ON P3A 5P3

CP 5000 SUCCA
200 RHE BRADY
SUDBURY ON P3A 5P3

705.671.2489

www.
citygreater.sudbury
.on.ca

Dear Mr. Chisholm:

Re: Petition - Pedestrian Lights at Lamothe Street & Barrydowne Road

At the City Council meeting of February 14, 2007, Councillor Landry-Altman submitted a petition to the City Clerk regarding the installation of pedestrian lights at the corner of Lamothe Street and Barrydowne Road, Sudbury.

This petition was forwarded to the Acting General Manager of Infrastructure and the Director of Roads & Transportation, for their review.

Yours truly,

A handwritten signature in cursive script that reads 'Corrie-Jo Caporale'.

Corrie-Jo Caporale
Council Secretary

cc: Councillor Landry-Altman
G. Clausen, Acting General Manager of Infrastructure
B. Falcioni, Director of Roads & Transportation

EXHIBIT: B

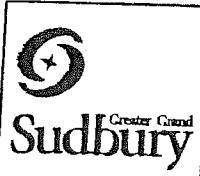
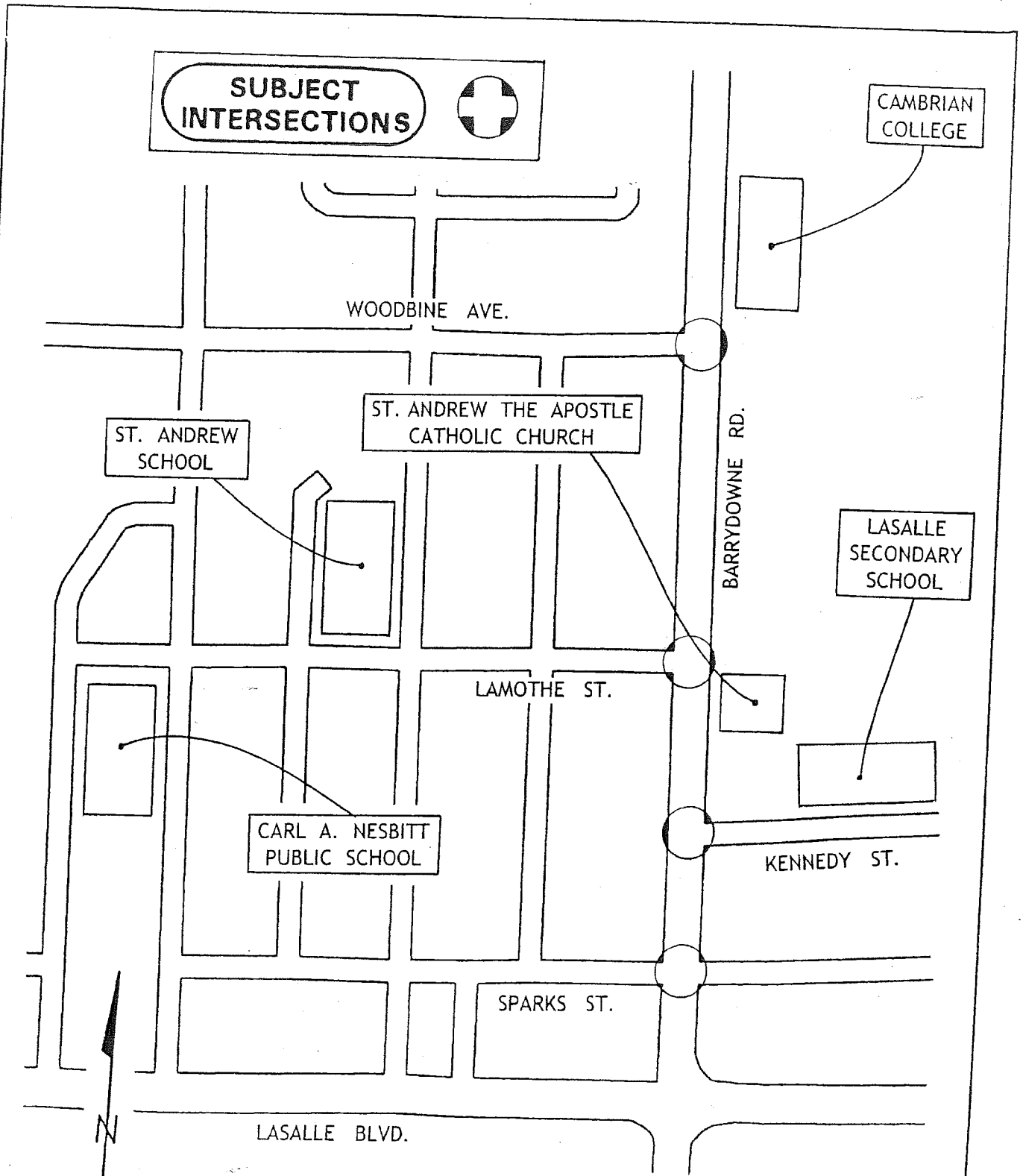

- 1) BARRY DOWNE RD. AT SPARKS ST., 2) BARRY DOWNE RD. AT KENNEDY ST.,
- 3) BARRY DOWNE RD. AT LAMOTHE ST., 4) BARRY DOWNE RD. AT WOODBINE AVE.

REQUEST FOR PEDESTRIAN SIGNALS

N.T.S.

EXHIBIT: C

Pedestrian Count Volume Summary

Location: Barry Downe Road @ Sparks Street
 Date of Count: 5/14/2007

Time	Unassisted Pedestrians	20% Assisted Pedestrians
8:30	7	2
9:30	6	2
11:30	4	1
12:30	3	1
13:30	5	1
16:00	6	1
17:00	10	2
18:00	4	1
Total	45	11

Factored 8 hour Ped Volume	67
8 hour Vehicle Volume on Street	7100

* Assisted Pedestrian = (Seniors, children under 12 and disabled pedestrians)
 Factored Ped volume = total unassisted volume + 2x total assisted volume

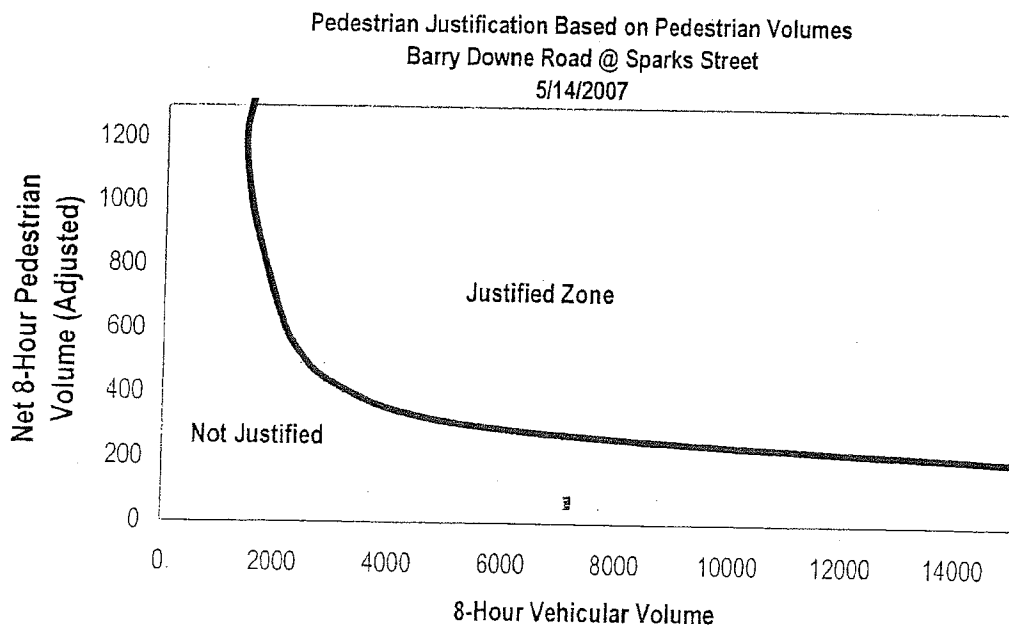

Pedestrian Count Volume Summary

Location: Barry Downe Road @ Kennedy Street

Date of Count: 5/11/2007

Time	Unassisted Pedestrians	20% Assisted Pedestrians
8:30	13	3
9:30	12	3
11:30	12	3
12:30	12	3
13:30	8	2
16:00	7	2
17:00	4	1
18:00	10	2
Total	78	19

Factored 8 hour Ped Volume

115

8 hour Vehicle Volume on Street

7600

* Assisted Pedestrian = (Seniors, children under 12 and disabled pedestrians)

Factored Ped volume = total unassisted volume + 2x total assisted volume

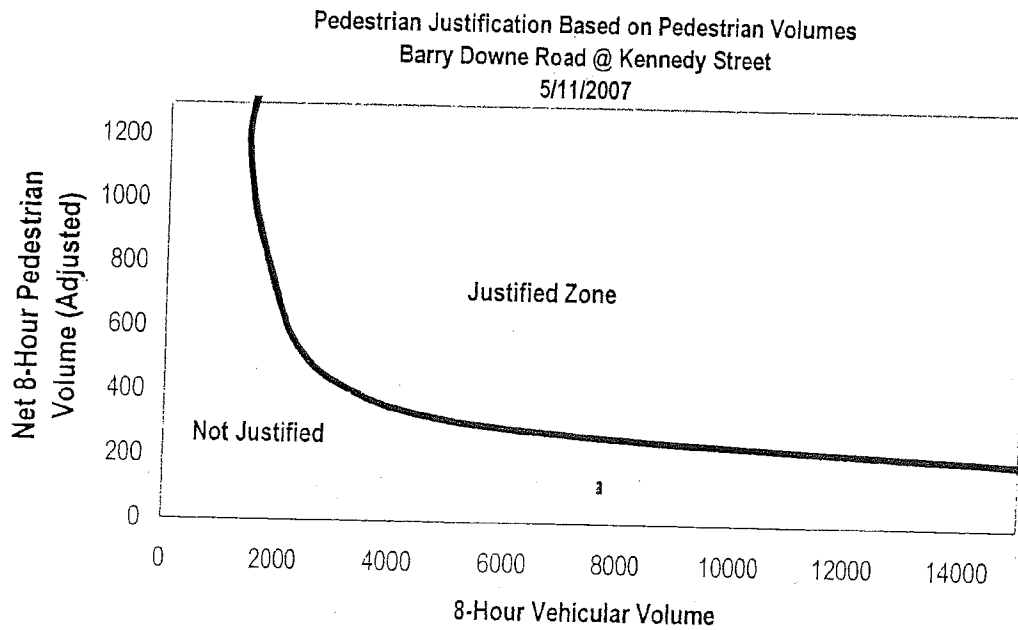

Pedestrian Count Volume Summary

Location: Barry Downe Road @ Lamothe Street
 Date of Count: 5/15/2007

Time	Unassisted Pedestrians	20% Assisted Pedestrians
8:30	10	3
9:30	2	0
11:30	5	1
12:30	2	1
13:30	5	1
16:00	6	1
17:00	4	1
18:00	9	2
Total	43	10

Factored 8 hour Ped Volume 63
 8 hour Vehicle Volume on Street 6500

* Assisted Pedestrian = (Seniors, children under 12 and disabled pedestrians)
 Factored Ped volume = total unassisted volume + 2x total assisted volume

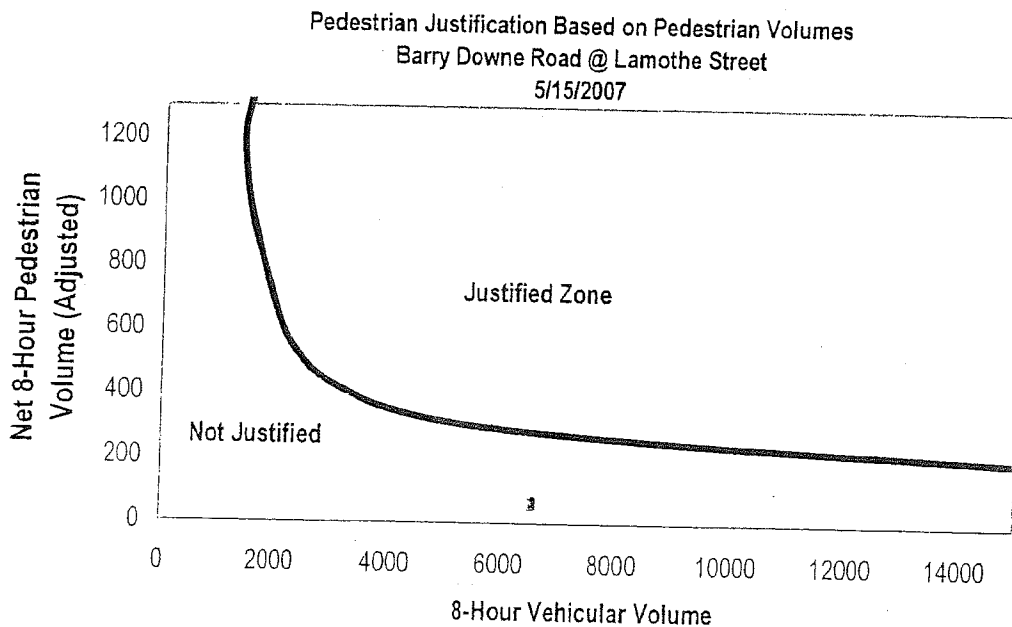

EXHIBIT: F

Pedestrian Count Volume Summary

Location: Barry Downe Road @ Lamothe Street (St. Andrew The Apostle Church)
 Date of Count: Sunday, June 3, 2007

Time	Unassisted Pedestrians	20% Assisted Pedestrians
8:30	11	3
9:30	8	2
10:30	13	3
12:30	14	3
Total	46	11

Factored 4 hour Ped Volume 68
 8-Hour Vehicle Volume on Stree 4800

* Assisted Pedestrian = (Seniors, children under 12 and disabled pedestrians)
 Factored Ped volume = total unassisted volume + 2x total assisted volume

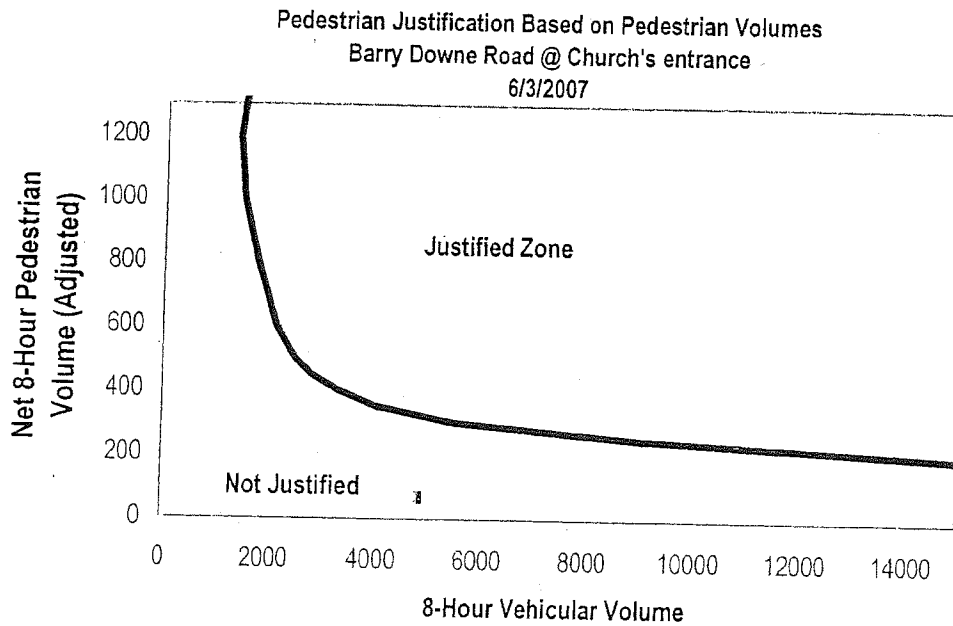

Pedestrian Count Volume Summary

Location: Barry Downe Road @ Woodbine Avenue

Date of Count: 5/10/2007

Time	Unassisted Pedestrians	20% Assisted Pedestrians
8:30	14	4
9:30	11	3
11:30	9	2
12:30	8	2
13:30	10	2
16:00	11	3
17:00	11	3
18:00	2	0
Total	76	19

Factored 8 hour Ped Volume

114

8 hour Vehicle Volume on Street

5400

* Assisted Pedestrian = (Seniors, children under 12 and disabled pedestrians)

Factored Ped volume = total unassisted volume + 2x total assisted volume

